

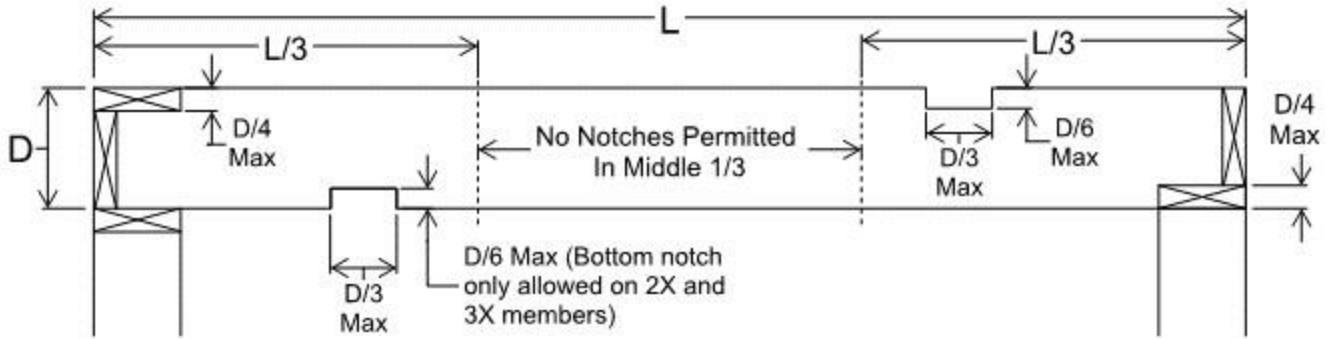

Notching and Boring of Framing Members

This Tip Sheet reflects code requirements of the 2018 International Residential Code (IRC).



Floor and Ceiling Joist Notching

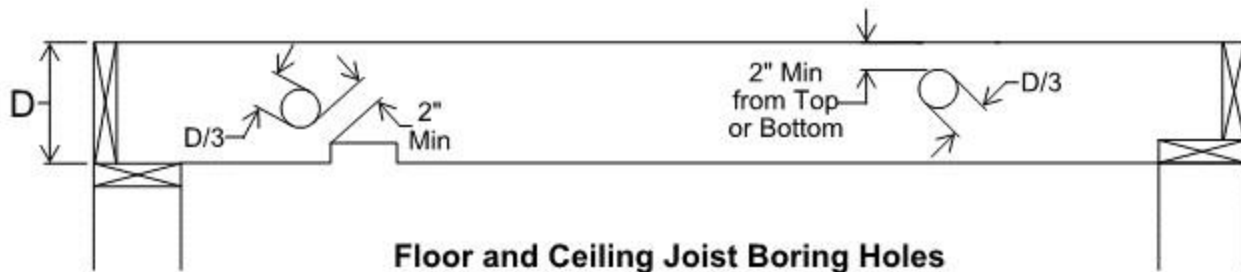

Floor and Ceiling Joist Boring Holes

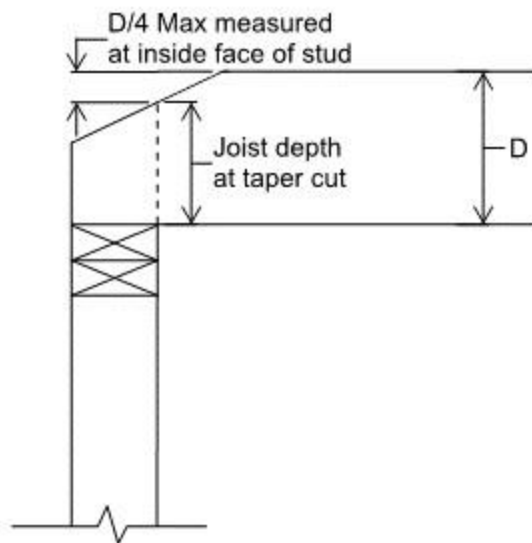

Ceiling Joist Taper Cutting

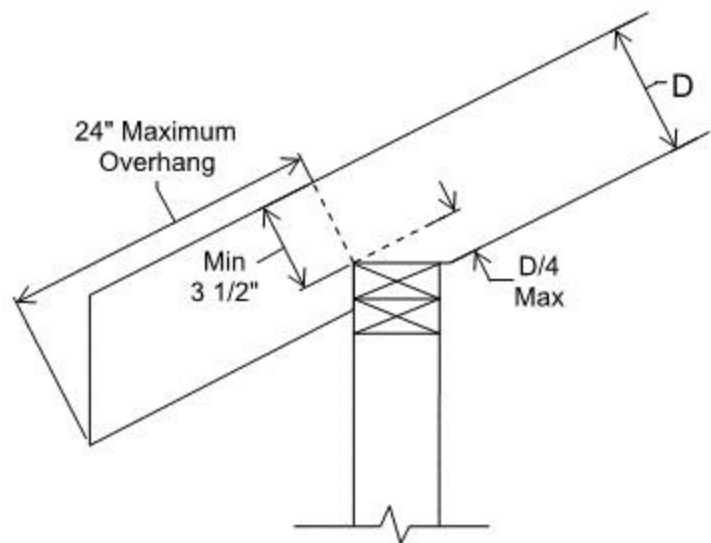

Rafter Notching

Figure 1: Floor Joists, Ceiling Joists, and Rafters (per IRC R502.8 and R802.7)

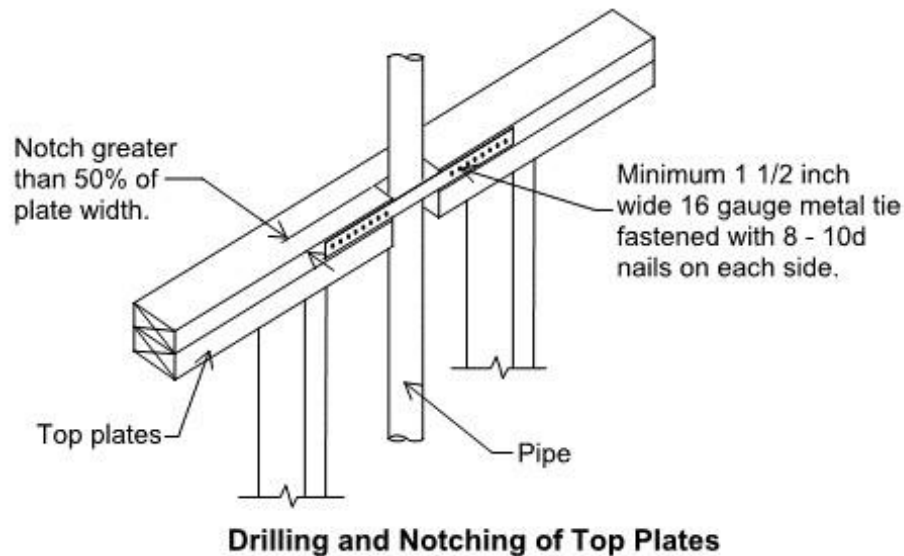
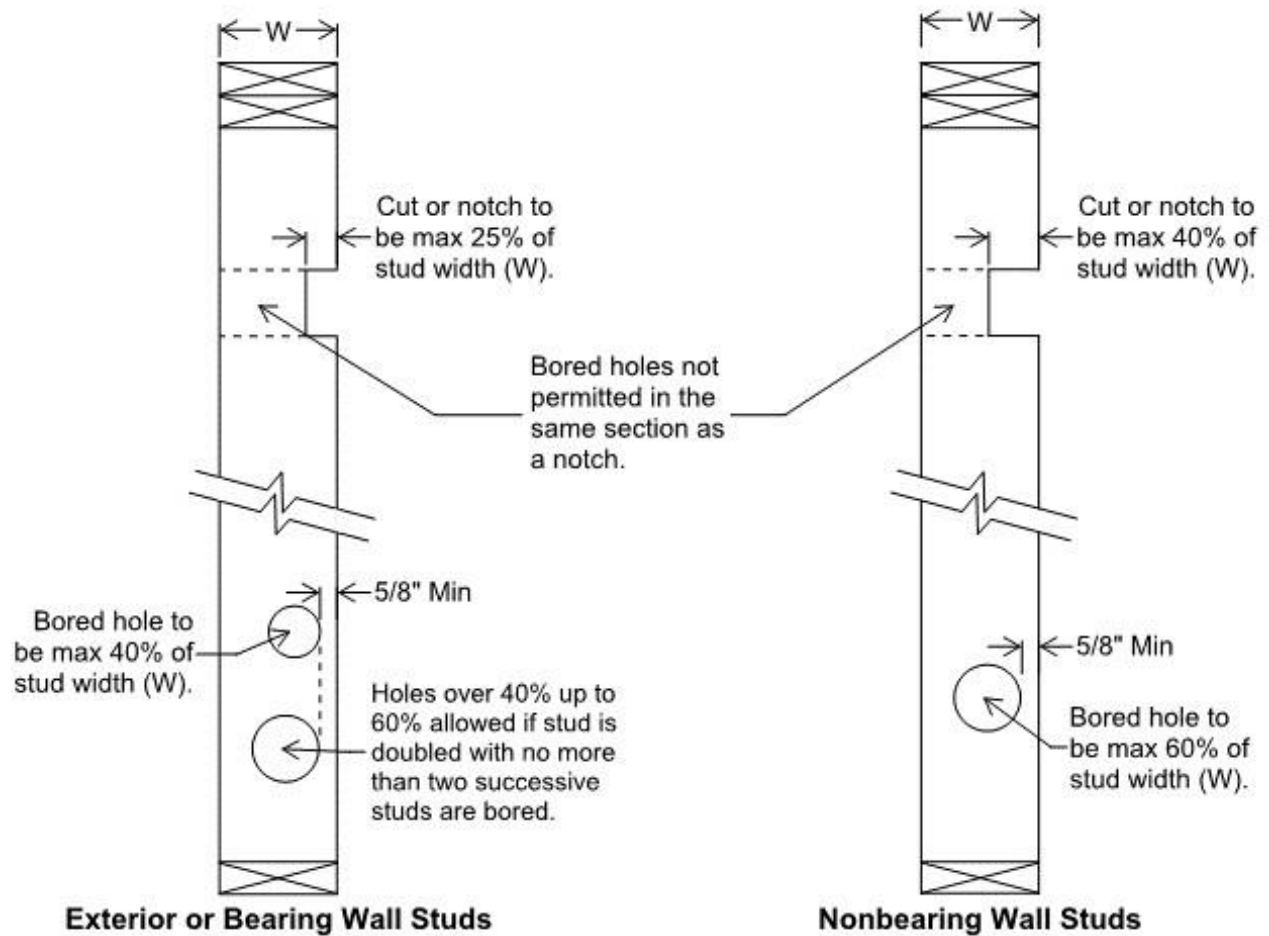

Figure 2: Studs and Top Plates (per IRC R602.6)